



Munich Personal RePEc Archive

Political accountability, incentives, and Contractual design of public private partnerships

Athias, Laure

IDHEAP, University of Lausanne, CES and GREGOR,
University of Paris 1 Sorbonne

02. December 2007

Online at <http://mpra.ub.uni-muenchen.de/10538/>

MPRA Paper No. 10538, posted 17. September 2008 / 20:52

POLITICAL ACCOUNTABILITY, INCENTIVES, AND CONTRACTUAL DESIGN OF PUBLIC PRIVATE PARTNERSHIPS: DEMAND RISK ON PRIVATE PROVIDERS OR PUBLIC AUTHORITIES?¹

Laure ATHIAS

ATOM, University of Paris Sorbonne

laure.athias@malix.univ-paris1.fr

laure.athias@yale.edu

ABSTRACT

Service adaptations, when there is changing demand or problems regarding the service provision, constitute a major issue in Public Private Partnerships (PPPs). So far, studies have explained the *ex post* adaptation problems by the distorted incentives for the private public-service provider to invest in adaptation efforts. However, as any PPP is between a public authority and a private public-service provider (no market price), public authorities have also an important role to play in the adaptation of the private public-service provision over time. This paper studies how the contractual design of PPPs affects accountability and incentives for contractually unanticipated service adaptations. More specifically, we observe worldwide two main different contracting out procedures: the concession contract and the availability contract. The main difference between these two contractual practices concerns the demand risk, which is borne by private providers in the first case and by public authorities in the second case. This paper shows that there are two main effects of the contractual design on accountability. (1) Concession contracts, compared to availability contracts, motivate more public authorities from investigating and responding to public demands. This is due to the fact that under a concession contract consumers are empowered, *i.e.* have the possibility to oust the private provider, which provides public authorities with more credibility in side-trading. (2) Concession contracts can give greater adaptation effort incentives to private providers than availability contracts, since, if private providers bear the demand risk, they can receive private gains from implementing the adaptation. The striking policy implication of this paper is then that the trend towards a greater resort to contracts where private providers bear little or no demand risk may not be optimal in terms of allocative efficiency.

JEL codes: D23, H1, L5, 017.

Keywords: Public Services; Public-Private Partnerships; Accountability; Consumers Empowerment; Government Responsiveness; Incomplete Contracts; Concession Contract; Availability Contract; Holdup.

¹ This paper started while the author was a visiting scholar at Yale and wishes to thank Eduardo Engel for his helpful comments.

This paper was presented at the invited session “Public Private Partnerships”, presided by J. Pouyet, at the 56th annual congress of the AFSE, Paris, September 19-21 2007.

The author gratefully acknowledges comments and suggestions from David Azema, Olivier Desbief, Pierre Garrouste, Vincent Piron, Jérôme Pouyet, Maher Said, Stéphane Saussier, and participants at the 56th annual congress of the AFSE, Paris, September 19-21 2007, and at the ATOM Research seminar.

1. INTRODUCTION

Reforming public-service delivery occupies a central position in the current policy agenda in the world. Public Private Partnerships (PPPs) are considered as an alternative model to the traditional public provision for public services, and they are now worldwide used². Nevertheless, many concerns have been raised regarding this emerging organisational model. The most stringent worries concern the *ex post* adaptation inflexibilities inherent to these long term contracts. Adaptation is important when consumers' preferences change and improved policies or technologies are discovered. For example, it is difficult to get a good idea of what reasonable standards of quality will be like in 20 or 30 years time. In many university accommodation contracts, the quality standards mention microwave cookers which could not have been written into a contract 20 years ago (McWilliam 1997). As the major feature of PPPs is that they are long-term service contracts, it is highly likely that contracting parties will be unable to write complete contracts that cover all contingencies, and numerous are the cases that offer good illustrations of the difficulties for procuring authorities to reaching an agreement with private public-service providers on contractually unanticipated service adaptations. It is often mentioned that “[a] key concern with long-term PPP contracts is the level of flexibility that they offer to authorities to make changes either to the use of assets or to the level and type of services offered” (PricewaterhouseCoopers 2005).

So far, studies have explained the *ex post* adaptation problems by the distorted incentives for the private public-service provider to invest in the research into innovative approaches to carrying out the service provision (Hart, Shleifer and Vishny 1997, Hart 2003, Bennett and Iossa 2006). Hart *et al.* (1997) show that if assets are owned by the private sector, then cost-reducing changes can be introduced without renegotiation, since the sole contract with the public sector is on services. Thus the full benefit of such changes flows to the private owner and encourages efficiency. In contrast, benefits that improve service quality require renegotiation and the public body may be in a position to extract part of the benefit since the private owner has no alternative purchaser for the incremental gain. The effect is that the private owner receives less of the benefit of such changes and the incentives are weakened.

None of them (except Ellman 2006) approach this issue from a political accountability point of view; none of them give an active role to public authorities. However, public authorities have also an important role to play in the adaptation of the private provision of public services over time for the following reasons. First, any PPP is between a public authority and a private public-service provider; that is there is no direct democracy (the public cannot vote directly to select and oust the private provider). Second, there is no market

² The surge in PPPs is reflected in the financial press. For example, articles in the Financial Times mentioning this concept increased twenty-fold over the last decade, from 50 in 1995 to 1,153 in 2004 (Engel *et al.* 2007). The case of PPPs in the transportation sector is particularly compelling. Recently, 20 U.S. states passed legislation permitting the operation of public-private partnerships to build, finance and operate toll-roads, bridges and tunnels. See “Paying on the Highway to Get Out of First Gear.” New York Times, April 28, 2005.

accountability of private providers, since the price applied to consumers, if any, is a regulated price, not a market price. Finally, public authorities, as elected delegates of consumers, are duty bound to discover adaptations and consumers' preferences and to exercise pressure on the private provider to adapt the public service to satisfy the changes in the effective consumers demand.

It seems then that political accountability, *i.e.* the responsiveness of public authorities to consumers concerns, has also to be considered when one aims to tackle the issue of the inefficient development of PPPs over time. In other words, we have to consider public authorities as active players instead of passive bystanders of the general efficiency of PPPs. Ellman (2006) is the first to theoretically raise the question of the accountability of public authorities in the adaptation over time of the private provision of public services. More precisely, in this paper, the author compares private with public provision regarding political and public accountability.

By contrast, in this paper, I investigate how the contractual design of PPPs affects accountability mechanism. More specifically, we can observe two main contract types for delegating public services to private operators: contracts where private providers bear no demand risk, designated as availability contracts, and contracts where private providers bear the demand risk, namely concession contracts, which have broadly the same meaning everywhere. Both are long-term, global contracts on the design, building, financing and operation of a public service (roads, bridges, schools, hospitals, prisons, government accommodation, computer systems, Ministry of Defence training simulators, and other activities) and consist in output specifications systems. Both types of contracts can be considered as fixed-price contracts (the procuring authority offers the private provider a prespecified price for completing the project in both contracts). They do not differ in the magnitude of implication of the private operator, both contracting procedures formally delegate to the private provider sufficient residual control rights to provide the service free of interference. The main difference between these two contractual practices concerns the demand risk, which is borne by private providers in the first case and by public authorities in the second case. Thus, under a concession contract, the private provider's remuneration depends on the demand for the public service whereas under an availability contract, it comes from service payments by the procuring authority according to performance criteria (the contract specifies penalties in case the performance and quality criteria are not met; there is therefore no link with the service demand).

The traditional model of PPPs in the world has been the concession contract. According to the World Bank private participation in infrastructure database, between 1990 and 2000, overall 65% of the projects in Latin America and the Caribbean were adjudicated as concessions. The concession contract is also the most common form of PPP in Europe except

in the UK, where, even though concession contracts are used, public authorities resort above all to availability contracts, designated by the acronym PFI “the Private Finance Initiative” and its successor the Public Private Partnerships (PPP) (Grout 1997, HM Treasury 2000). But the concession contracting model has increasingly come under fire in recent times in developing countries as well as in developed countries (Engel *et al.* 2002, 2006, Guasch 2004, Estache 2006). The main criticisms are related with the high incidence of renegotiation observed under these contracts due mainly to the demand overestimation, strategic or not, by private providers in their bids (Athias and Nunez 2007). The trend has been therefore to not impose the demand risk on private providers anymore. Availability contracts are therefore increasingly being adopted around the world to move away from the concession model. This is particularly pronounced in Europe, where countries have recently promulgated guidelines so as to bring in the availability contract as an alternative to the concession contract, e.g. the June 2004 act in France instituting the new “contrats de partenariat”.

While it is commonly thought that availability contracts are used when it is not possible to make users pay or when the services are not profitable, we observe in practice, on the one hand, that some contracts specify that the service provider is remunerated according to the service demand even if users do not pay (they are most often known under the name “shadow toll contracts”) and, on the other hand, that procuring authorities resort to availability contracts, and hence make the remuneration of the service provider dependent on continuity of service supply, while users pay a toll to them. Thus, it appears that the choice between a concession and an availability contract, that is to say between a contract in which the private provider bears the demand risk and a contract in which it does not, depends neither on the ability to make users pay nor on the profitability of the service in question.

Whereas the literature has been prolific regarding the concession contracts and their potential pitfalls, very few have been said about availability contracts. It is nonetheless possible to draw some lessons from the experiences in the UK. Over 900 PFI projects with a capital value of £40bn have been signed in the UK, with about 500 of them operational (HM Treasury 2004).

To investigate how the contractual design of PPPs – availability *versus* concession contracts – affects not only private providers’ incentives to adapt the service provision, but also, and above all, public authorities’ incentives to be responsive to consumers concerns, I present an incomplete contract theory model in which: (1) public authorities (e.g. government, mayors) are involved in adaptation, *i.e.* exert effort to respond to consumers demands; (2) consumers may have the power to sanction the private manager; (3) private providers exert efforts to cut costs and to discover adaptations.

First, I show that public authorities end up having to pay more for unanticipated desirable service adaptations when the private provider does not bear the demand risk than when it

does. This is due to the fact that under a concession contract consumers are empowered, *i.e.* have the ability to sanction and oust the private provider, which provides public authorities with more credibility in side-trading and thus greater incentives to be responsive. Second, I show that contracts where private providers bear the demand risk most often dominate contracts where they bear little or no demand risk regarding private providers' cost reducing incentives. This is due to the fact that when the demand risk is on private providers, they may have some incentives to internalise the effects of their cost-reducing investments. Third, I show that concession contracts can give greater adaptation effort incentives to private providers than availability contracts. This is due to the fact that there might be private gains from implementing the adaptation under a concession contract, so that the private provider will implement the adaptation without any further inducement.

As a consequence, I show that there is a lower matching with consumers preferences over time under an availability contract than under a concession contract. In other words, I show that contracts in which private providers do not bear the demand risk rule more out the accountability – regarding service adaptations – of public authorities and providers to individual consumers than when they bear the demand risk. The striking policy implication of this paper would be that the trend towards a greater resort to availability contracts, or more generally to contracts where private providers bear little or no demand risk, so as to avoid the high renegotiation incidence observed under concession contracts, may not be optimal. This is all the more true that the belief that private providers do not bear a demand risk in availability contracts could be an illusion.

The main contribution of this paper is to highlight the importance, so far neglected, of the political accountability in the private public-service provision, and to shed some insights into the impact of the contractual design of PPPs on this accountability mechanism. In addition, this paper also contributes to the broader literature on the political economy of government responsiveness. It is in fact related to the literature on voucher provision of public services and demonstrates that empowering consumers of public services strengthens incentives for governments to be responsive.

The paper is organised as follows. Section 2 presents the related literature. In section 3, I illustrate the underlying logic in the context of three examples. Section 4 presents the basic model of political accountability under both types of private provision and solves it. Section 5 extends the model with the endogeneisation of the effort of the private provider and discusses the complementarity or substitutability of public authorities' and private providers' incentives. Section 6 extends the model with the consideration of the risk of default of public authorities when private providers do not bear the demand risk. Section 7 discusses the results and speculates about the application of the analysis to different sectors. Section 8 concludes.

2. RELATED LITERATURE

My work is linked to the incomplete contract literature, while focusing on the contractual design, instead of ownership structures. Hart *et al.* (1997) show that if assets are owned by the private sector, then benefits that improve service quality require renegotiation and the public body may be in a position to extract part of the benefit since the private owner has no alternative purchaser for the incremental gain. The effect is that the private owner receives less of the benefit of such changes and the incentives are weakened. As a consequence, Hart (2003) advocates that, where build contracts are easy to specify but service contracts are not, then it is useful to have a conventional provision (“unbundling” of the construction and operation stages). At the other extreme, where service contracts are easy to write and build contracts are difficult, the PPP approach may be particularly sensible. Bennett and Iossa (2006), in turn, show that PPPs will be optimal only when the innovation in the construction stage has a positive externality on operation and maintenance costs.

In contrast with these studies, I approach the issue of contractually unanticipated service adaptation not only from the point of view of the distorted incentives for the private public-service provider, but also from a political point of view. Ellman (2006) is the unique author to our knowledge that theoretically raises the question of the accountability of public authorities in private provision of public services. More precisely, in this paper, the author compares private with public provision regarding political and public accountability. To this end, he relies on the framework of Hart, Shleifer and Vishny (1997) but considers that the government and the public are involved in service adaptation. He shows that privatisation can, first, demotivate the government from investigating and responding to public demands because privatisation allows the provider to hold up service adaptations, and, second, demotivate the public from mobilising to pressure for service adaptations, since providers indirectly hold up the public by inflating the government’s cost of implementing these adaptations. Thus, in this paper, the tradeoff is between public and private provision. In his model, privatisation takes implicitly only one form, the form of the availability contract (he assumes that private providers’ remuneration never depends on the demand), and private providers’ adaptation incentives do not vary with the governance structure. My model adds two novel features to the set-up of Ellman (2006): (1) consumers may have the ability to sanction and oust the private public-service provider according to the contractual design of PPP; (2) private providers’ adaptation incentives vary with the governance structure.

My work is also linked to the literature on the political economy of government responsiveness. For instance, Besley and Burgess’s (2001 and 2002) model derives how governments become more responsive to people when people become more aware of how government actions affect them, which is determined by the freedom of the press. Also, Besley and Ghatak (2003) tackle the question of the best process by which service providers,

consumers and procuring authorities come together to create an organization. This could be governed by choice, as when a parent picks a school for their child, or by government policy. The authors show, in a non formalized way, that empowering consumers, by allowing them to choose between providers with different service provisions, is a potentially source of welfare improvements. They explain that empowering consumers means that the nature of the principal-agent problem changes. While the centralized model of public-service provision (illustrated in Figure 1) has two layers of agency problems: between consumers and elected officials and between the government and the service provider, the structure of the problem when consumers of public services are empowered (as shown in Figure 2), provides a closer link between them and service providers. Thus, empowering consumers can offer a better matching between consumers and providers, in other words a greater allocative efficiency.

Figure 1

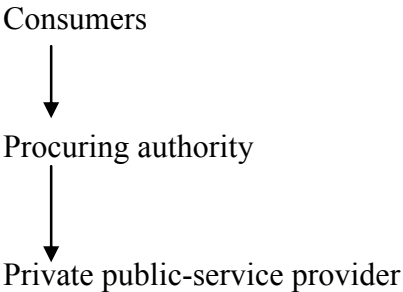
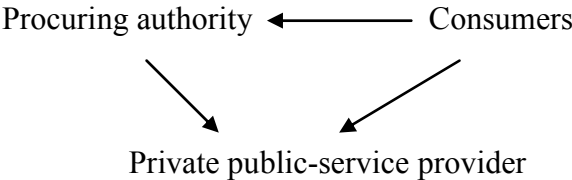

Figure 2



This approach underpins the representation developed in this paper of the accountability mechanism for service adaptations under the two differing contractual procedures. While the centralized model of public-service provision illustrated in Figure 1 corresponds to the accountability structure implied by an availability contract, the model in which consumers are empowered (Figure 2) fits with the accountability structure of a concession contract (or more generally of models in which private providers bear the demand risk, e.g. shadow toll contracts). As a matter of fact, under concession contracts, consumers are empowered to the extent that the remuneration of the private provider depends on the demand for the service. Thus, under such contracts, consumers have the power to oust the service provider by not using the service any more, depending on the availability of alternative options. Making the private provider bear the demand risk can then empower consumers, which can then lead to a better alignment on service provision preferences.

3. EVIDENCE

This section illustrates the underlying logic of the paper in the context of three case studies.

3.1. THE SCHOOL CATERING CASE

The recent experience of the British government with school dinners offers a good example of the incentives provided by an availability contract, *i.e.* a contract in which the private provider does not bear the demand risk. According to Ellman (2006), “In the aftermath of a series of television reports on school dinners by celebrity chef Jamie Oliver in early 2005, the government rushed to quench mounting public discontent over low quality committing to make improvements. However, new schools locked into 25-year contracts through private finance initiatives (PFIs) are finding that they cannot rid their menus of junk food despite the government’s pledge”.

This case highlights the fact that, under an availability contract, if there is a shock in demand like a fundamental change in the consideration of healthy food by the public, the procuring authority has very low power to make the private provider adapt the service accordingly. By contrast, we can imagine that if the demand risk was on the private provider, *i.e.* its remuneration depends on the demand for the public service (in contrast to the fixed payment if performance criteria are met), the public would have had the possibility to oust the private provider in case of non-adaptation to their demand by, for instance, providing their children with a home-made lunch. This would have had consequently increased the credibility of the procuring authority to sideline the incumbent private provider for not adapting to healthier ingredients.

This logic also applies in the following case of the London Underground Public Private Partnership.

3.2. LONDON UNDERGROUND PUBLIC PRIVATE PARTNERSHIP

The London Underground Public Private Partnership is a long-term PFI contract that provides for maintenance and upgrading work of the London underground (trains, tracks, signalling and stations). This is a thirty-year, £30bn contract between London Underground Limited and the main private service provider Metronet. Metronet holds two of the three thirty-year contracts to maintain track and trains covering the London underground network. One contract covers the Bakerloo, Central, Victoria and Waterloo & City deep-level Tube lines; the other covers the Metropolitan, District, Circle and other sub-surface lines that run in shallow tunnels. The service provider took over responsibility for the lines in April 2003. It followed a competitive process whereby the contract was awarded to the qualified bidder offering the specified service at the lowest price (availability charge). Monthly payment to Metronet derives from a performance adjusted Infrastructure Service Charge (ISC). In other words, the payment to Metronet, for the first period of the contract (the contract is divided in 4 periods of 7,5 years), is composed of a fixed ISC (94,6% of the revenues determined for the first period) and of performance revenues (that account for 5,4% of the revenues determined for the first period of the contract). The performance revenues depend on the execution of the

renewal works. They are determined according to the statistics of incidents and performance of the two last years preceding the contract. There are four criteria:

(+) *Capability*: technical capability of the lines, maximal capacity to reduce the durations of the trips;

(+) *Availability*: time lost by users (trains speed reduction);

(+) *Ambience*: global service quality perceived by, assessed by independent surveys;

(-) *Service points and Specific Projects*: penalties are applied in case of failure to meet the specified standards (regarding mainly trains delayed).

75% of the performance revenues stem from technical improvements (Capability).

Moreover, in case of disputes, the contract specifies the intervention of an independent "Statutory Arbiter", designated by the Secretary of State.

The extent of Metronet's problems has been clear since November 2006, when the arbiter of the PPP contract said he expected the company to overspend by £750m in the first 7½ years of its contract, up to October 2010. Mr Livingstone, London's Mayor, has for long assumed that London Underground would end up paying none of the £750m of overspending. Yet, Metronet is moving closer to initiating a formal independent review to decide who pays for a projected £750m cost overrun. Andrew Lezala, of Metronet Rail, went on: "I respect the fact that there are large sums involved here and we are quite prepared to go through the extraordinary review process, and that's quite likely" (Robert Wright, April 25 2007).

Whereas the grounds of this overspending are not clear, this case however highlights the fact that, in the framework of availability contracts, when there are *problems* regarding the service provision (not only regarding contractually unanticipated service adaptation), it is very difficult for the procuring authority to reach an agreement with the private provider. In this particular case of London Underground Public Private Partnership for instance, the private provider is not afraid to face a long settlement of dispute and huge costs. We could however imagine that if the demand risk was on Metronet, users would have been able to sanction Metronet for delivering a service of bad quality, and hence empowered London Underground in the negotiation process.

3.3 COFIROUTE: THE EPISODE OF THE "SHIPWRECKED MEN OF THE ROAD" OF SAINT-ARNOULT-IN-YVELINES

Cofiroute is the main French highway concessionaire. They operate under concession contracts, *i.e.* their remuneration depends on the demand for the highway and more particularly stems from the tolls charged to users.

January 4, 2003, the French Weather-Forecaster underestimates the extent of the falls of snow which will fall down on the French North and Centre, preventing the installation by Cofiroute of the provisions necessary to preserve the viability of base joint A10-A11. Thus, when plates of glaze appeared on this joint base, already dense circulation became completely blocked. The absence of measures such as the diversion of traffic and information of the users by Cofiroute increased the number of users blocked out of 60 km.

After this event, there was a public discontent about the lack of suitable means in case of considerable falls of snow. As a consequence, Cofiroute invested in less heavy salting vehicles as well as in automatic salting systems located in crucial points.

Thus, in contrast with the former ones, this case study highlights the fact that under a concession contract, in case of changing public demand or problems, service adaptation can occur.

Thus, these various case studies highlight the fact that the underlying problem with availability contracts is that they often prevent the procuring authority from exploiting adaptation gains in the absence of the private provider's cooperation. If a crucial change in demand or a fundamental problem in the way the public service is provided occurs, procuring authorities have very low power to lead private providers to adapt the service provision. This might be explained by the low credibility in side-trading procuring authorities have. By contrast, under a concession contract, consumers have the power to oust private service providers by sidelining them with alternative options. This strengthens the credibility of procuring authorities to replace or sideline the incumbent private provider for not adapting to consumers demands or dealing with provision problems, since in case of sidelining, the incumbent can experience negative profits (waste of economies of scope in side-trading are then largely reduced). So, it seems that under availability contracts, private providers can hold up the procuring authority from a greater share of its gain from adaptation than under concession contracts. This is what the model developed in the following section proposes to show.

4. THE MODEL

This section presents a simple model of the choice by procuring authorities between availability and concession contracts for the provision of a public service by a private provider (such as health care, transportation, water, education or school dinner catering), derived along the lines of Ellman (2006). I consider first the model in which the private public-service provider does not make any effort to adapt the service. I endogenise the accountability of procuring authorities (politicians) to changing consumers' demands by

introducing a third party (the consumers of the public service) within Hart, Shleifer and Vishny's framework.

So, in the model, there are two players: a procuring authority PA (e.g. a mayor, local government, or the national government) and the private service provider PM (private manager), and a special third player, the users of the public service (the consumers) C , that can influence PA and PM but cannot contract with them. More specifically, I assume in this model that consumers play a role only through their ability to sanction the private provider when the latter bears the demand risk. In other words, consumers are considered as a semi-player to the extent that I do not analyse the interactions between them and public authorities, assuming that public authorities always reflect consumers' preferences. Such an assumption is motivated by the fact that we consider core public services, to which consumers are very sensitive, and hence the adaptations they require are most often politically salient.

PA organises the service provision on the consumers' behalf. PA always delegates the service provision to a private manager (PM), but can choose between a contract in which the private provider does not bear the demand risk (an availability contract) and a contract in which the private provider bears the demand risk (e.g. a concession contract) to do it. Both contracting procedures formally delegate to the private provider sufficient residual control rights to provide the service free of interference, and they both are long-term contracts (we assume of the same length). Nevertheless, under both types of contract, PA and PM may still need to negotiate to adapt their contract over time. So, ongoing negotiation is needed for adaptation in both cases.

As already mentioned, there is one crucial difference between these two contractual forms. Under availability contracts, the remuneration of the private provider is not dependent on the demand but stems from service payments from PA according to performance criteria. By contrast, by imposing on the private public-service provider bear the demand risk (either through users' toll or through payments from PA depending on the demand, as in shadow toll contracts), concession contracts empower consumers, *i.e.* make it possible for consumers to sanction PM to the extent that if they do not use the service it provides, the private provider's remuneration is affected. Nevertheless, we cannot speak about "direct democracy" in the sense that the contract remains between PA and PM only, neither about market accountability since the price (or toll if consumers pay) paid to PM for the provision of the public service is the price regulated by the contract (not a market price). Thus, under both types of contract, if an adaptation is required, not only the adaptation but also and above all the price adaptation will have to be negotiated between PA and PM . Service adaptation can therefore occur only if PA and PM reach an agreement on the adaptation and the price adaptation. The hope is then that PA will pressure PM to adapt the public service to satisfy the changes in the effective demand. The demand/availability distinction matters because it

affects what happens when PA and PM have to negotiate to make PM adapt to unanticipated changes in the service provision.

4.1. BENCHMARK MODEL

At the start of their relationship, PA and PM negotiate a basic contract X , that can be either an availability contract or a concession contract. I assume that X just compensates PM for standard costs of provision, whatever the contractual design.

I do not consider the cost of public funds because, in both contractual procedures, the funding can either stem from users' tolls or from public funds. I am only interested in whether the private provider bears the demand risk (in which case PM 's remuneration can stem from public funds as in shadow-tolls contracts or from users' tolls) or not (in which case PM 's remuneration can stem from users' tolls that are collected by PA or from public funds).

X generates a (net) payoff of b for PA and $w(e)$ for PM where $w(e)$ is PM 's cost advantage (over a standard provider) from investing e in specialising to PA ³. In other words, I assume that this cost-reduction investment e by PM is fully relationship-specific, *i.e.* if PM does not provide some service for PA , neither PM nor PA gets any benefit from e . I assume that e is bounded so $e \in [0, \bar{e}]$. As in HSV's model, I assume that this cost-reduction investment is accompanied by a reduction in quality $q(e)$ ⁴.

The investment e is not contractible and nor is his payoff implications $w(e)$ and $q(e)$. The following regularity assumptions guarantee sufficiency of first-order conditions.

Assumption 1. $w(0) = 0$, $w''(e) < 0 < w'(e) \forall e \geq 0$ and $\lim_{e \rightarrow 0^+} w'(e) = \infty, \lim_{e \rightarrow \infty} w'(e) = 0$.

Assumption 2. $q(0) = 0, q'(e) \geq 0, q''(e) \geq 0 \forall e \geq 0$.

Assumption 3. $w' - q' > 0$, *i.e.* the net effect of cost reducing investments is always positive⁵.

Availability contract: the private provider does not bear the demand risk

Under an availability contract, PM 's overall payoff is $t_0 + w(e) - e$, where t_0 is the payment that PM receives for the provision of the basic public service. PM does not internalise the adverse quality effect $q(e)$ as quality is noncontractible.

PA 's overall payoff is then $b - t_0 - q(e)$.

³ Since in both contractual designs, PM has control rights over the service provision, e will be implemented unilaterally.

⁴ However, it is not obvious that the quality effects of cost-reducing investments are only negative. Nevertheless, considering positive effects on quality of e will not change the results of our model.

⁵ This assumption may be strong but as I assume that e is bounded, it is not that restrictive to assume that this assumption holds everywhere in the domain. It is in fact much less restrictive than assuming e is unbounded and that this assumption holds everywhere, like in Hart, Shleifer and Vishny's and related models. This assumption implies that we consider only public services for which PM 's cost-reducing efforts provoke quality damages that are always smaller than the gains in cost reduction they entail. This assumption seems however to match the features of numerous public services for which quality criteria are contractible *ex ante*.

Concession contract: the private provider bears the demand risk

Under a concession contract, consumers are empowered to the extent that they can oust the private provider in case of non satisfaction with the service provision. The magnitude of this faculty depends mainly on the availability of alternative providers.⁶ So I use the parameter λ to capture the impact of the pressure exercised by consumers on PM 's remuneration, where $\lambda \in [0,1]$.⁷ For $\lambda = 0$, it is not necessary that all consumers switch to an alternative provision to make PM experience negative profits. Indeed, the profitability of most concessions contracts is very sensitive to the demand, *i.e.* a marginal change of the demand can generate negative profits for the private provider.

Under such a contract, PM will then internalise the negative effect on quality of his cost-reducing effort according to the value of λ . For instance, if we consider the case when $\lambda = 0$, PM would not make any revenue if it does not internalise the quality effect of its cost-reducing investment. Thus, in such a case, PM will internalise the full adverse quality effect $q(e)$. Conversely, if $\lambda = 1$, PM will not at all internalise the adverse quality effect of e , since its remuneration would be the same whether internalising $q(e)$ or not.

Thus, if the impact of the pressure exercised by consumers on PM 's remuneration is λ , PM 's overall payoff is

$$t_0 + w(e) - (1 - \lambda)q(e) - e$$

$$PA \text{ 's overall payoff is then } b - t_0 - \lambda q(e).$$

4.2. ADAPTATION AND POLITICAL ACCOUNTABILITY

While PM invests e to cut costs, PA , as elected delegate of consumers, invests effort i to discover what the consumers want and how to satisfy their demands. So i represents PA 's efforts to pay attention to consumers concerns about service quality. For instance, when there is a consumers' demand for a concrete change, i raises the probability that PA recognises that the demand is serious and raises the probability that PA works out how to satisfy consumers demands – in terms of pressure exercised on PM to satisfy the change in effective consumers demand for instance. This effort permits then PA and PM to adapt the basic contract X to changing consumers' preferences.

I assume that consumers pressure is independent of PA 's attentiveness and contractual design.⁸

⁶ Note that it is not necessary that the alternative provisions are adapted to consumers' preferences. Consumers can in fact decide to switch to an alternative provision that can even less match their preferences, so as to sanction the private provider.

⁷ This boils down to assuming that the demand shock of an adaptation can only be negative. In other words, we assume that private providers' remuneration is bounded and can only be reduced by the changing demand.

⁸ I neglect the effort investments of consumers to discover improved policies and technologies because Ellman (2006) already models the public's role in creating accountability and proves that private providers indirectly

I denote the corresponding adapted contract by Z , again with the non-contingent transfer set to just compensate the standard cost of provision. For simplicity, I assume that e helps PM to satisfy Z so that PM 's net payoff from enforcement of contract Z is again $w(e)$. In other words e reduces PM 's costs by the same amount whether providing the basic or the adapted service. I also assume that e has the same adverse effect on quality $q(e)$ whether providing the basic or the adapted service. PA 's additional surplus from Z is $v(i)$ where $v \geq 0$, increasing and concave in i , represents the net gain in consumers welfare from the adaptation. In other words, $v(i)$ measures PA 's success in identifying or discovering adaptations that are valued by consumers⁹. So $v(i)$ can be interpreted as a measure of PA 's responsiveness to consumers demand – how likely it is that PA manages to please consumers. Attentiveness i raises PA 's ability and propensity to respond.

If PA pays PM subsequent transfers (or toll increases) t in case of adaptation, then, normalizing time discounting to zero, PA and PM 's overall payoffs from Z are:

When PM does not bear the demand risk

$$u_{PA} = b - t_0 - q(e) + v(i) - t - i$$

$$u_{PM} = t_0 + t + w(e) - e$$

When PM bears the demand risk

$$u_{PA} = b - t_0 - \lambda q(e) + v(i) - t - i$$

$$u_{PM} = t_0 + t + w(e) - (1 - \lambda)q(e) - e$$

The investment i is not contractible and nor is its payoff implications $v(i)$. The following regularity assumption guarantees sufficiency of first-order conditions.

Assumption 4. $v(0) = 0, v'(i) < 0 < v'(i) \forall i > 0$ and $\lim_{i \rightarrow 0^+} v'(i) = \infty, \lim_{i \rightarrow \infty} v'(i) = 0 \forall i \geq 0$.

Parties are risk-neutral and PA has rational expectation about the renegotiation process when it makes its investments, *i.e.* it can make correct calculations about the expected returns from any action. I assume information is symmetric and PM and PA negotiate a symmetric Nash bargain.¹⁰ So Z is enforced in equilibrium. Contractual design and the availability of

holdup consumers by inflating the procuring authority's cost of implementing these adaptations. Thus, the higher the hold-up of the procuring authority's gains from adaptation, the lower the pressure of consumers. Considering consumers' effort will therefore not change the results but will strengthen the dominance of the contract for which the procuring authority's incentives are higher. In addition, we can consider that consumers have always binding time and budget constraints.

⁹ If we consider that procuring authorities are not benevolent and then have for only objective the maximisation of their re-election chances, the adaptations required by consumers will have to be also politically salient. Again, I do not consider the case when consumers' and public authorities' benefits from adaptation are not proportional to the extent that I consider core public services, to which consumers are very sensitive.

¹⁰ Thus, following Hart-Shleifer-Vishny (1997), I assume that the public authority does not maximize the global surplus during renegotiations: its utility function is given by the welfare of the rest of society, excluding the private operator. A justification for this is that the political process aligns the public authority's and society's interests (since the private operator has negligible voting power, his interests receive negligible weight). Of

alternative providers matter because they affect default outcomes in bargaining and hence the equilibrium choices of i and e . I capture these effects in a simple four-stage model. **Timing:**

Stage 1: PA chooses the contract design (Concession contract, Availability contract) for contract X and negotiates with PM over stage 4 contract X , fixing the basic remuneration of the service provider t_0 .

Stage 2: PA and PM sink their investments i and e . I assume for now that the private provider does not invest in the research into innovative approaches to carrying out the service provision; this assumption is dropped in Section 5.

Stage 3: Renegotiation takes place to allow the adaptation to be implemented in the service provision: PA and PM negotiate over stage 4 the contract Z and additional transfer t (or toll increases).

Stage 4: PA and PM trade (jointly or with their market alternatives).

The remuneration t_0 agreed at stage 1 cannot depend on observed investments, for it is not possible to specify in advance the delivery of a specific adaptation. So it plays no role in determining investment efficiency. The subsequent transfer t , negotiated on top of contract Z at stage 3, is the share of PA 's adaptation surplus that PA in equilibrium has to give to PM , in excess of its adaptation costs. It depends on the stage 3 default payoffs which in turn depend on the contractual design and availability of alternative providers, as I will show.

PM is assumed to maximize its profits. PA maximizes the social benefit, net of the payment to PM . In this setting, the first-best levels of investments (e^*, i^*) maximize $b + v(i) - i + w(e) - q(e) - e$. Hence, they satisfy

$$v'(i^*) = 1$$

$$w'(e^*) - q'(e^*) = 1$$

with $e^*, i^* > 0$.

As both contracts are with a private provider, in default of renegotiation, I assume that PA is not able to exploit entirely investments i . This is due to the fact that under each type of contractual design, PA and PM commit to X at stage 1, they cannot therefore switch to alternative trades (except if they break the contract, which is prohibitively expensive). PA might however still engage in "side-trades" with other private or public providers PM' to provide the service adaptation alongside the basic public service provided by PM (this might be possible either through the implementation of a new provider, or through the resort to

course, if the government placed the same weight on the private operator's utility as on the rest of society, the first-best could be achieved.

already available alternative provisions).¹¹ Nevertheless, this market access by PA is rarely so effective: (1) PA may not be able to credibly duplicate the basic service by buying the adapted service from PM' unless the additional value from adaptation is very high; (2) even when it is technologically feasible to have PM' provide the adaptation service without the basic service, this would waste the economies of scope from having a single party provide and coordinate them. To capture PA 's reduced market access, I assume that PA only appropriates a fraction $(1-k)$ of the adaptation return $v(i)$ ¹², where $k \in]0,1[$ captures the “market-shielding” effect of PPP. This actually boils down to an asset-specificity effect. In addition, PM 's side-trading returns are independent of i and e , so I normalise PM 's additional side-trade value to 0.

4.2.1. Effort when the private provider does not bear the demand risk

Under an availability contract, PA 's default payoff is:

$$b - t_0 + (1 - k)v(i) - q(e)$$

Normalising PM 's alternative payoff to 0, PM 's default payoff is $t_0 + w(e)$. This is due to the fact that the contract protects PM 's cost-reduction efforts, by forcing PA to pay a fixed price for the basic service, provided that performance criteria are met. So PM appropriates the full cost reduction $w(e)$.

PA 's maximal gain from renegotiation is therefore $kv(i)$.

PA and PM 's renegotiation gains are $\frac{1}{2}$ of this sum. So PA chooses i to maximise

$$b - t_0 + (1 - k)v(i) - q(e) + \frac{1}{2}[kv(i)] - i \quad (1)$$

and PM chooses e to maximise

$$t_0 + w(e) + \frac{1}{2}[kv(i)] - e \quad (2)$$

The first-order conditions are now

$$v'(i) = \frac{2}{2 - k} \quad w'(e) = 1 \quad (3)$$

4.2.2. Effort when the private provider bears the demand risk

When the contract imposes the demand risk on the private provider, in case of non adaptation, consumers can sanction the private provider. The magnitude of this faculty depends on the availability of alternative providers (in the case of a highway, we can imagine that users, if their changing demand is not satisfied, can sanction the private provider by using another

¹¹ I assume that PM' 's additional cost of providing the adapted service is the same as for PM . Furthermore, I assume competition is such that PA needs only to compensate PM' 's costs.

¹² Recall that $v(i)$ is PA 's net benefit, *i.e.* entails PM 's costs of adaptation.

road, or by taking the train etc. See also the above example with school catering). So, again, I use the parameter λ to capture the impact of the pressure exercised by consumers on PM 's remuneration, with the availability contract being equivalent to the setting $\lambda = 1$ ¹³.

Under such a contract, PA has more power and credibility to exploit investments i . In fact, consider that the number of consumers that switch to an alternative provider in case of default of renegotiation is such that $\lambda = 0$, implying no profits for PM . In such a case, PA is able to appropriate the full margin return $v(i)$ by negotiating with PM' (no market-shielding effect any more) because PA is able to switch – instead of side-trading – to alternative trading. Thus, if the impact of the pressure exercised by consumers on PM 's remuneration is λ , PA 's default payoff is

$$b - \lambda t_0 + (\lambda(1-k) + (1-\lambda))v(i) - q(e)[1 - \lambda(1-\lambda)] = b - \lambda t_0 + (1-k\lambda)v(i) - q(e)[1 - \lambda(1-\lambda)]$$

In default of renegotiation, PM may not appropriate the full cost reduction $w(e)$. This is due to the fact that consumers will switch to alternative provisions, which, in the case of a concession contract, will lead to lower profits for PM , and hence a weaker internalisation of $w(e)$ by PM . In addition, PM may also suffer from the adverse effect on quality $q(e)$ of the cost reduction effort e , but, in case of default, only regarding the consumers that still use the service even if it is not adapted. PM 's default payoff under a concession contract is then

$$\lambda[t_0 + w(e) - (1-\lambda)q(e)]$$

PA 's maximal gain from renegotiation is therefore

$$\lambda k v(i) + (1-\lambda)w(e)$$

The gain from renegotiation is shared between the parties through a Nash-bargaining solution, so PA chooses i to maximise

$$b - \lambda t_0 + (1-k\lambda)v(i) - q(e)[1 - \lambda(1-\lambda)] + \frac{1}{2}[k\lambda v(i) + (1-\lambda)w(e)] - i \quad (4)$$

and PM chooses e to maximise

$$\lambda[t_0 + w(e) - (1-\lambda)q(e)] + \frac{1}{2}[k\lambda v(i) + (1-\lambda)w(e)] - e \quad (5)$$

The first-order conditions are now

$$v'(i) = \frac{2}{2-\lambda k} \quad w'(e) - q'(e) \left[\frac{2\lambda(1-\lambda)}{(\lambda+1)} \right] = \frac{2}{\lambda+1} \quad (6)$$

4.3. ACCOUNTABILITY AND INCENTIVES COMPARISONS

4.3.1. Political accountability

¹³ I abstract from the transaction costs of designing an availability contract compared to a concession contract, which when $\lambda = 1$ would favour the concession contract. See the discussion part.

The above first-order conditions demonstrate how a contract in which the private provider bears the demand risk increases PA 's incentives to support adaptations from the marginal incentive $(2-k)/2$ of $v'(i)$ in equation 3 to $(2-\lambda k)/2$ of $v'(i)$ in equation 6. Under an availability contract, PM is able to hold up PA of its investments i , because PA is not totally able to exploit i by replacing or sidelining an uncooperative PM . Under a concession contract, PM can also be able to hold up PA , but it will depend on the value of λ . More specifically, the greater the impact of the pressure exercised by consumers on PM 's remuneration, *i.e.* the smaller λ , the smaller the renegotiation surplus for PA , so the smaller the holdup of PM of PA 's adaptation investments. In the case of $\lambda = 0$, PA 's incentives to support adaptations when the private provider bears the demand risk, are equivalent to the first-best incentives level. Accordingly, $i^* \geq i^{ConcessionContract(CC),\lambda} \geq i^{AvailabilityContract(AC)}$ for any λ . The following proposition records these points.

Proposition 1. *Procuring authorities are more attentive and responsive to consumers demand when the private provider bears the demand risk. Increasing the impact of the pressure exercised by consumers on PM 's remuneration increases the political accountability. So, $i^{CC}(\lambda) > i^{AC} \forall \lambda < 1$, and $\frac{di^{CC}(\lambda)}{d\lambda} < 0 \forall \lambda > 0$.*

Proof. See Appendix

The proposition, illustrated by the following Figure 3, states that the model in which the private provider bears the demand risk (like in concession contracts) always dominates the model in which the private provider does not bear any demand risk (like in availability contracts) regarding the political accountability, *i.e.* regarding the incentives given to the procuring authority to invest efforts to pay attention to consumers changing demands. Intuition follows from the fact that the procuring authority has more credibility in side-trading under a concession contract than under an availability contract, since the incumbent private provider can experience negative profits.

Figure 3: Illustration of equilibrium levels of political accountability

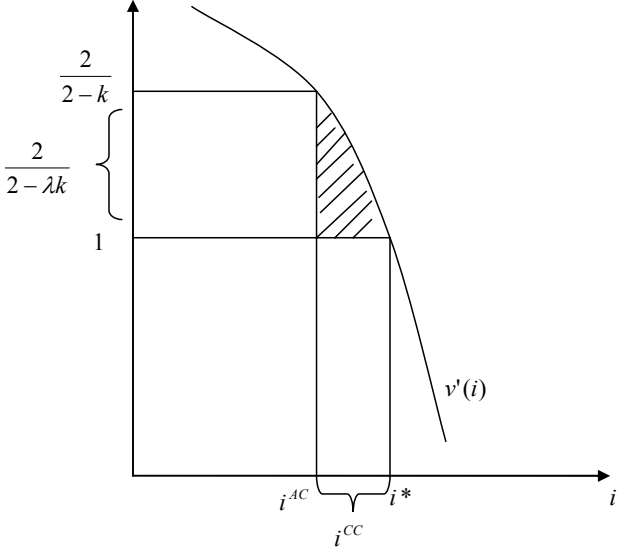

4.3.2. Private provider's cost-reducing incentives

The above first-order conditions also demonstrate how a concession contract decreases PM 's cost-cutting incentives compared to an availability contract. As a matter of fact, the model shows that for λ equal to 1, PM 's cost-cutting incentives under a concession and under an availability contract are equivalent and over-optimal. However, when λ tends towards 0, PM 's cost-cutting incentives under a concession contract, e^{CC} , tend to be smaller than under an availability contract. They may become exactly equal to e^* for some λ and then continue to decrease and get further away so that, for a range of values of λ , there is under-investment in e under a concession contract. Finally, e^{CC} may be, for λ close to zero, further away from e^* than e^{AC} is. The following Figure 4 and proposition illustrate and record these points.

Figure 4: Illustration of equilibrium levels of private providers' cost-reducing incentives

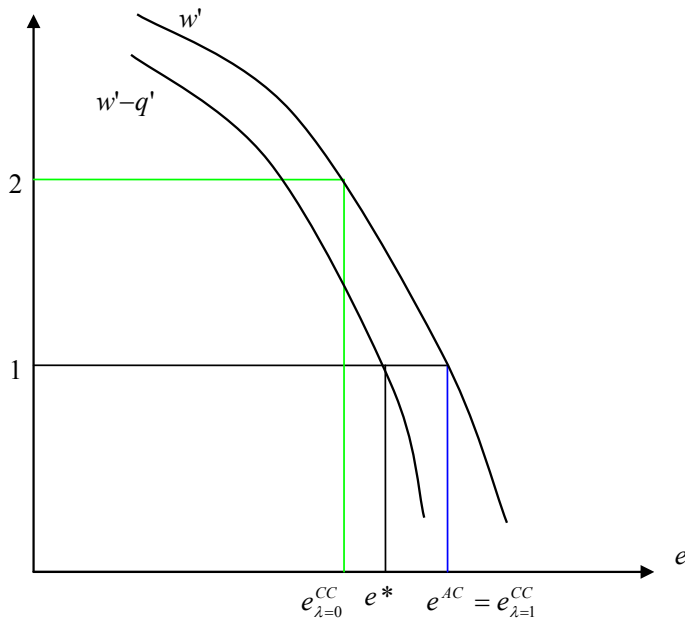

Proposition 2. i) *The private public-service provider's incentives to invest in cost-reducing efforts are smaller when it bears the demand risk than when it does not, i.e. $e^{AC} \geq e^{CC}$ for any λ . Whether the private provider bears the demand risk or not is optimal depends on the value of λ and on the functional forms for $w(e)$ and $q(e)$. Without making further assumptions about the functional forms for $q(e)$ and $w(e)$, it is not possible to pin down a particular value of λ that makes the contractual forms equally inefficient.*

ii) *Increasing the impact of the pressure exercised by consumers on PM 's remuneration, i.e. a smaller λ , decreases its incentives to invest in cost-reducing efforts, i.e.*

$$\frac{de^{CC}(\lambda)}{d\lambda} > 0 \forall \lambda > \frac{1}{4}$$

Therefore, when $\lambda > \frac{1}{4}$, there is a unique value of λ^ for which the two contractual forms are equally distant from the first best for each form for $w(e)$ and $q(e)$. Below this cut-off λ^* , the contract in which the private provider does not bear the demand risk is optimal,*

and above this cut-off, the contract in which the private provider bears the demand risk is optimal.

iii) Since $e^{AC} \geq e^{CC}$ and $e(\lambda)$ is increasing $\forall \lambda > \frac{1}{4}$, there is a range of values of λ around 1 where the contract in which the private provider bears the demand risk is always closer to the first best than the contract in which the private provider does not bear the demand risk.

Proof. See Appendix

Intuitively, if the private provider bears the demand risk, it internalizes the negative externality of e according to the potential impact of the consumers' pressure on its remuneration. By contrast, under an availability contract, in case of adaptation or not, PM never internalises the adverse quality effect. Then, PM 's cost reducing efforts under a concession contract can only be lower than under an availability contract.

In addition, the greater the impact of consumers' pressure on PM 's remuneration, the more PM will internalize the negative externality and then the smaller e ; conversely, the lower the potential impact of the pressure exercised by consumers on PM 's remuneration, the lower the internalisation by the private provider of the adverse effect on quality of its cost reducing investments and hence the higher its cost reducing efforts.

However, this does not imply that the concession contract always dominates the availability contract. As a matter of fact, if λ tends towards zero, there is under-investment in e under a concession contract, and for λ close to zero, depending on the functional forms for $w(e)$ and $q(e)$, PM 's cost-reducing incentives when it bears the demand risk might be further away from e^* than when it does not bear the demand risk. This is due to the fact that in case of non-adaptation and λ close to zero, PM will not be able to internalise $w(e)$.

The fact that PM may not be able to appropriate the full $w(e)$ in case of default of adaptation when it bears the demand risk explains why availability contracts will be always more optimal than concession contracts *if we do not consider the effect of cost-reducing efforts on quality* (since under an availability contract, in case of adaptation or not, PM always appropriates the full cost-reduction effort).

The consequence is that clear-cut results are not obtained when we consider the adverse effect of e on quality. Whether the private provider bears the demand risk or not is optimal depends on the functional forms for $w(e)$ and $q(e)$. Thus, without making further assumptions about the functional forms for $w(e)$ and $q(e)$, it is not possible to pin down a particular value of λ , λ^* , that makes the two contractual forms equally inefficient. However, *for a particular form for $w(e)$ and $q(e)$* , it is easy to pin down the λ^* that makes the two contractual forms equally inefficient. The following Figures 5 and 6 give also *an illustration*

of the situations where a contract in which the private provider bears the demand risk is either always optimal (Figure 5), or not always optimal (Figure 6).

Figure 5: Case where the concession contract is always optimal.

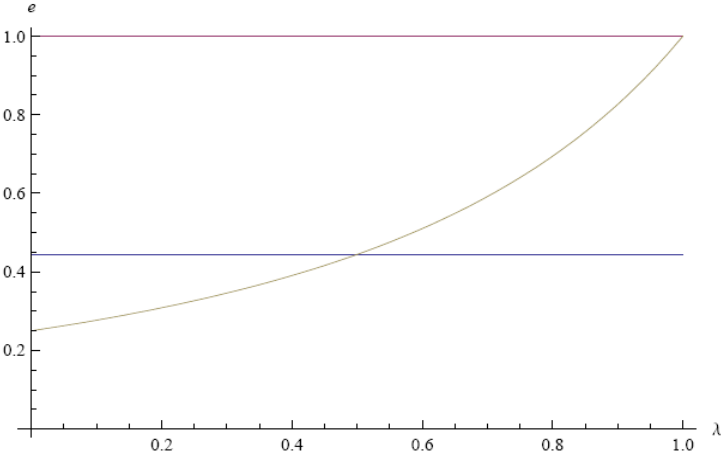

In this example, we have $w(e) = 2\sqrt{e}$ and $q(e) = \frac{e}{2}$ (then the assumptions are satisfied for all $e < 4$). We have then $e^* = \frac{4}{9}$ (blue line), $e^{AC} = 1$ (red line), $e^{CC} = \frac{1}{(2-\lambda)^2}$ (yellow line). Then, for all λ , the concession contract is closer to efficiency than the availability contract.

Figure 6: Case where the concession contract is not always optimal.

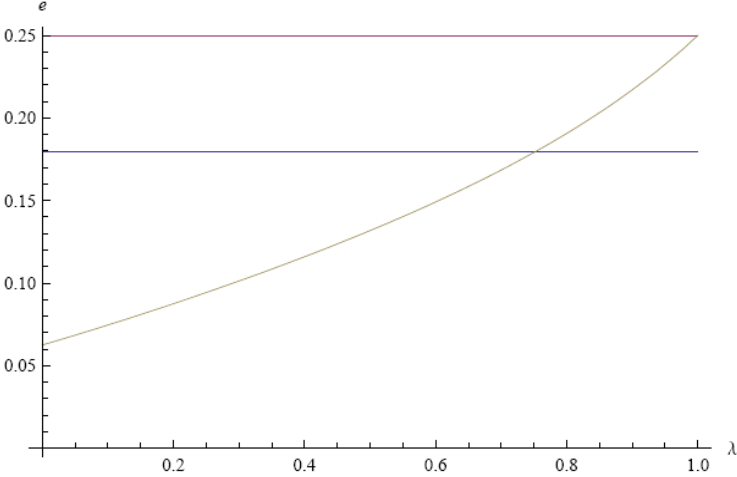

As for the case where the concession contract is not always optimal, let consider $w(e) = \sqrt{e}$ and $q(e) = \frac{e^2}{2}$. We can see that for smaller values of λ , the concession contract is farther from the first-best than the availability contract. In particular, the λ^* that makes the two contractual forms equally inefficient is approximately 0.355569.

In addition, these figures illustrate the fact that there is a range of values of λ around 1 where the contract in which the private provider bears the demand risk is always closer to the first best than the contract in which the private provider does not bear the demand risk.

In sum, I have shown that *it is always optimal to impose the demand risk on the private provider regarding the incentives given to procuring authorities to be accountable*. As for the incentives given to the private provider to reduce costs, there are cases (depending on the impact of the consumers pressure on the private provider's remuneration and on the functional forms for the positive and negative effects of the private provider's cost-cutting efforts) where the contract form such as the concession contract does not dominate the contract form such as the availability contract. In such cases then, a tradeoff occurs between imposing on the private provider the demand risk to raise the accountability and responsiveness of procuring authorities to consumers concerns, and not imposing on the private provider the demand risk to raise its cost-cutting incentives. Otherwise, when the conditions for such cases are not satisfied, the model in which the private provider bears the demand risk always dominates the model in which it does not.

5. ENDOGENOUS PRIVATE PROVIDER'S EFFORT

So far, I have neglected *PM*'s potential role in discovering adaptations whereas many studies have highlighted the importance of *PM*'s incentives to invest in the research into innovative approaches to carrying out the service provision (e.g. Hart, Shleifer and Vishny 1997, Besley and Ghatak 2001, Hart 2003, Bennett and Iossa 2006).

If we consider that it is not in *PM*'s interest to implement a quality innovation without renegotiating with *PA* over the split of the surplus generated by such an innovation, *i.e.* if we assume that *PM* has no private gains from implementing the adaptation, *PM*'s adaptation incentives would not vary with the contractual design structures I analyse.

However, if we now relax the assumption that *PM* has no private gains from implementing an adaptation, the contractual design may have an impact on *PM*'s adaptation investment incentives.

5.1. *PM*'S ADAPTATION EFFORT UNDER AN AVAILABILITY CONTRACT

Under an availability contract, it is straightforward that *PM* has no incentives to support the cost of adaptation efforts without negotiating with *PA* over the surplus sharing. This is due to the fact that the remuneration of *PM* under an availability contract is fixed, provided that *PM* meets the quality and performance criteria included in the contract, so that *PM* receives no private gains from implementing the adaptation.

5.2. *PM*'S ADAPTATION EFFORT UNDER A CONCESSION CONTRACT

Under a concession contract, if *PM* invests in adaptation effort *j* without any negotiation with *PA* over the surplus generated by such an investment, *PM*'s payoff is

$$t_0 + w(e) - (1 - \lambda)q(e) - j.$$

If *PM* does not invest in adaptation effort and then does not adapt the service according to consumers' demand, his payoff is $\lambda[t_0 + w(e) - (1 - \lambda)q(e)]$. In fact, in default of adaptation, consumers will switch to alternative adapted provisions whenever possible, which, in the case of a concession contract, will lead to lower profits for *PM*.

PM's maximal gain from adaptation is therefore $(1 - \lambda)[t_0 + w(e) - (1 - \lambda)q(e)] - j$.

Thus, since *PM* has control rights, it will implement the adaptation whenever it receives private gains from doing so, *i.e.* whenever the following condition is met

$$(1 - \lambda)[t_0 + w(e) - (1 - \lambda)q(e)] > j \tag{7}$$

This condition implies that, if the demand shock (e.g. taste shock), reflected by λ , is large (*i.e.* λ tends towards 0) and that the corresponding cost shock, reflected by j , is small (*i.e.* j tends towards 0), then *PM* will have incentives to support j without any negotiation with *PA* over the surplus generated by his investment, because it will receive private gains from doing so.

This leads to the following proposition:

Proposition 3. *If $(1 - \lambda)[t_0 + w(e) - (1 - \lambda)q(e)] > j$, *i.e.* if the demand shock tends to be large and the cost shock of the adaptation tends to be small, then the private provider has more incentives to invest in adaptation efforts under a concession contract than under an availability contract.*

This proposition is consistent with existing evidence on how concession contracts are working. For example, the main private concessionaire of highways in France has implemented a new radio station in order to offer better real-time information to users on the traffic, without renegotiating with the government any toll adaptation. While interviewing this private provider, it admitted that he had incentives to implement the innovation because the cost of the implementation was low and the consequent impact on demand could be large so that it expected private gains from doing so.

This proposition shows that when the private provider bears the demand risk, it can have, under certain conditions, a direct accountability to consumers; that is even if the contract remains between the procuring authority and the private provider, some market accountability is feasible.

5.3. COMPLEMENTARITY AND SUBSTITUTABILITY IN ACCOUNTABILITY

The model shows that, under certain conditions, a concession contract increases both *PA*'s accountability and *PM*'s incentives regarding non anticipated service-provision adaptation. The question that is raised now is to know whether these efforts are complementary or

substitutes. In fact, it could be useless to speak about political accountability if *PM*'s incentives could be enough to make *PM* adapt the public service to satisfy the changes in the effective consumers demand.

First, the model shows that when the demand shock of an adaptation is small and the corresponding cost shock is large, *PM* does not receive any private gains from implementing the adaptation, *i.e.* it will not have any incentives to implement the adaptation unilaterally. In such a case then – which is most often the case, *PM* and *PA* will have to renegotiate the contract and a greater *PA*'s accountability increases the probability that the adaptation implemented will please consumers.

Second, even when the conditions that make *PM* adapt the service unilaterally when it bears the demand risk are satisfied, *PA*'s accountability and *PM*'s incentives can be complementary. As a matter of fact, even if there is no renegotiation over whether to implement the adaptation since *PM* will implement the adaptation without any further inducement, *PA* and *PM* can communicate over the adaptation itself (e.g. over the actual change in consumers preferences) because a better knowledge by *PM* of the consumers preferences can increase *PM*'s private gains. In such a case, the greater is *PA*'s attentiveness, the more sense it makes for *PM* to investigate how to satisfy consumers demand. Conversely, the greater *PM*'s efforts, the more *PA* can gain from investigating consumers concerns and being responsive to them. Thus, some degree of complementarity can be present and hence the model in which the private provider bears the demand risk can even more dominate the model in which it does not bear the demand risk, as highlighted by the following proposition.

Proposition 4. *If political accountability and private public-service provider's efforts in adaptation are complements, then this complementarity raises the benefit from imposing the demand risk on the private provider. It has no effect on e .*

6. DEMAND RISK OR DEFAULT RISK

So far, we have considered that the payments from *PA* to *PM*, provided that performance criteria are met, are guaranteed when the private provider does not bear the demand risk. But this absence of “demand risk” under contracts such as the availability contract could be an illusion. As a matter of fact, the payments to *PM* depend on *PA*'s budget, *i.e.* on the capacity of *PA* to pay. So we can imagine that in periods of tiny budgets, *PA* might have some problems to pay *PM* when the latter does not bear the demand risk¹⁴. We can expect that the likelihood of such a default risk will be higher in less developed countries than in

¹⁴ I consider in this section that when the private provider bears the demand risk, his payments do not depend on the procuring authority's budgets (it means that I exclude from the analysis the shadow toll contracts).

developed countries. Nevertheless, when procuring authorities are local entities, such a risk can occur whether the country is wealthy or not (e.g. the city of Angoulême in France that went bankrupt in 1991, and was then unable to honour any of its commitments).

So let consider now the possibility of a default risk when the private provider does not bear the demand risk. In particular, I use the parameter γ to capture the probability of the absence of procuring authorities' default risk, with $\gamma \in [0,1]$ ¹⁵. While this parameter might affect PM 's cost-reducing incentives, it will not have any impact on the political accountability. Therefore, repeating the exercise of the section 4 and focusing on PM 's cost-reducing incentives, we have PA and PM 's overall payoffs from Z :

$$u_{PA} = b - \gamma(t_0 + t) - q(e) + v(i) - i$$

$$u_{PM} = \gamma(t_0 + t + w(e)) - e$$

PA 's default payoff is then $b - \gamma t_0 - q(e) + (1 - k)v(i)$

PM 's default payoff is $\gamma(t_0 + w(e))$

PA 's maximal gain from renegotiation is therefore $kv(i)$.

PA and PM 's renegotiation gains are $\frac{1}{2}$ of this sum. So PM chooses e to maximise

$$\gamma(t_0 + w(e)) + \frac{1}{2}[kv(i)] - e \tag{8}$$

The first-order conditions is now

$$\gamma * w'(e) = 1 \tag{9}$$

The above first-order condition demonstrates how an availability contract decreases PM 's cost-cutting incentives compared to a concession contract when $\gamma \leq \frac{1}{2}$. As a matter of fact, the model shows that for γ equal to $\frac{1}{2}$, PM 's cost-cutting incentives under an availability contract are equivalent to the ones under a concession contract for $\lambda = 0$ and under-optimal. However, when γ tends towards 0, PM 's cost-cutting incentives under an availability contract tend to be smaller than under a concession contract, since the effort of the private provider under an availability contract is increasing in γ . So we need λ^* to increase so as to rebalance the two contractual forms. As this process continues and γ gets small, λ^* gets high, and hence the concession contract tends to be more often optimal.

When $\gamma \in \left[\frac{1}{2}, 1\right]$, the efforts under a concession contract can be superior or inferior than the efforts under an availability contract. More specifically, the concession contract will be more optimal for intermediate range of values of λ , whereas for extreme values the availability contract will be more optimal.

This leads to the following proposition:

¹⁵ Thus, when $\gamma = 1$, it means that the likelihood of procuring authorities' default risk is equal to zero and, conversely, when $\gamma = 0$, the likelihood of default risk is equal to one.

Proposition 5. For $\gamma \leq \frac{1}{2}$, as the likelihood of default risk of public authorities gets high, i.e. γ gets small, λ^* is weakly increasing, i.e. the contract in which the private provider bears the demand risk tends to be more often optimal.

In addition, increasing the likelihood of PA's default risk, i.e. a smaller γ , decreases PM's incentives to invest in cost-reducing efforts.

Proof. See Appendix

Intuitively, if the private provider bears the risk of default of the procuring authority, it may not be able to internalize the positive effect of e . More precisely, the higher the likelihood of default of the procuring authority, the less PM will internalize the positive effect and then the smaller e ; conversely, the lower the likelihood of default of the procuring authority, the greater the internalisation by the private provider of the cost savings of its cost reducing investments and hence the higher his cost reducing efforts. PM 's efforts are then increasing in γ .

In sum, considering the potentiality of default of procuring authorities tends to make the concession contract be more often optimal than the availability contract, under certain conditions, regarding the cost-cutting incentives of the private provider. This might explain why we do not observe as many availability contracts in less developed countries as in developed countries, since the default risk of procuring authorities in such countries can be very high (γ tends towards zero). However, as already highlighted, such a default risk can also occur in developed countries (e.g. when the procuring authority is a local entity) but the probability of occurrence is lower than in less developed countries.

7. DISCUSSION

Overall, the model highlights that contracts in which the private provider does not bear the demand risk, even though they permit to reduce the likelihood of renegotiation – to the extent that low demand realizations are often at the heart of opportunistic renegotiations initiated by firms –, are not always optimal. In other words, I have pointed out that there is a tradeoff between using concession contracts to raise private providers' and public authorities' incentives to be responsive to consumers concerns, and resorting to availability contracts to limit the likelihood of renegotiation. Thus, this tradeoff will mainly depend on the following criteria: (a) the possibility for consumers to exercise pressure on private providers' revenue, (b) the default risk, and (c) the likelihood of renegotiation.

Taking into account these three criteria, it is possible to make some predictions on the contractual form that would best fit a particular sector.

7.1. SPECULATION

Let first consider the case of water supply. In such a case, the availability of alternative provisions for consumers is rather limited (they can however still buy bottles of water). Thus, procuring authorities cannot credibly threaten the incumbent private provider in side-trading it in case of default of adaptation of the service provision. Are availability contracts then better suited to this sector? The tradeoff will depend on the likelihood of renegotiation versus the likelihood of default of the procuring authority.

For road projects, consumers have most often the choice between alternative provisions (e.g. trains, alternative roads), so that the impact of the consumers' pressure on the private provider's remuneration can be significant¹⁶. Concession contracts will therefore dominate availability contracts regarding the allocative efficiency. However, the quality of roads is largely contractible, so that we can expect a very low effect of cost-reducing investments on quality. The model highlights that when there is no effect of cost-reducing investments on quality, availability contracts always dominate concession contracts regarding the incentives of the private provider to cut costs. In addition, the uncertainty associated with future traffic is very high and exogenous (Pickrell 1990, Flyvbjerg and Skamris 1997, Athias and Nunez 2007), making toll road concessions particularly prone to renegotiation issues (Engel *et al.* 2002, 2006, Guasch 2004, Estache 2006). A clear prediction in this sector is therefore not possible, but will tend to favour the use of availability contracts in this sector.

By contrast, we can expect that contracts in which the private provider bears the demand risk will be more suitable for the management of schools (included school catering services) and hospitals where there is a diversity of provisions and a low uncertainty on the future demand.

These results are generally consistent with existing evidence on how PFI is working, compared to concession contracts. According to a report commissioned by the Treasury Taskforce (Arthur and Andersen and Enterprise LSE 2000), PFI appears to have worked well for roads, generating substantial cost saving, though it has worked less well for schools and hospitals.

7.2. A CONTINUUM CHOICE OF CONTRACTS RATHER THAN BINARY

It is contractually possible to restrict the demand risk imposed on the private provider within a concession contract (Athias and Saussier 2007), so that public authorities do not face a binary choice of contracts but a continuum choice.

However, this does not question the results I obtained to the extent that the weaker the extent to which the private provider bears the demand risk, the weaker the potential impact of

¹⁶ Again, and particularly in the road sector, a marginal variation in the demand can be sufficient to generate negative profits for the private provider.

the consumers' pressure on its remuneration, *i.e.* the higher the λ , and hence the weaker the advantages to resort to concession contracts, everything else being equal.

7.3. VOUCHER PROVISION, TRANSACTION COSTS AND POLITICAL ACCOUNTABILITY

The model developed in this paper underpins the standard argument for voucher provision of public services. The state provides the citizens with a voucher that entitles the individual to a particular service (or it could be a monetary amount) and they then choose where to spend that voucher. A better matching between consumers and providers is therefore reached. This attenuates incentive problems and increases organizational efficiency by economizing on the need for explicit incentives. This can explain why the transaction costs of designing a contract in which the private provider bears the demand risk are much lower than those associated with the design of a contract in which the private provider does not bear the demand risk.

This paper also addresses the broader question of how to increase the political accountability and more specifically if it is possible to increase the political accountability by empowering the consumers, *i.e.* by allowing them to oust a firm when this one bears the demand risk. I show that, in the particular case I analyse, the political accountability is higher when consumers are empowered.

7.4. COMPARISON WITH THE PUBLIC PROVISION

While Ellman (2006) finds that it is always optimal to have in-house provision relative to contracting out provision regarding the political and public accountability, I show that under some conditions, the contracting-out model in which the private provider bears the demand risk might dominate the public provision since it allows political accountability as well as cost-reducing investments.

8. CONCLUSION

In this paper, I have studied the effects of imposing the demand risk on the private provider on the accountability of procuring authorities regarding consumers changing demands and on the adaptation effort incentives of the private public-service provider. Thus, not only private providers, but also public authorities, can be expropriated *ex post* of a part of the surplus generated by their efforts to investigate and satisfy consumers' changing demand.

The model shows that the contract form in which the private provider bears the demand risk always dominates the one in which it does not bear the demand risk regarding the incentives given to procuring authorities and private providers to be responsive to consumers concerns.

As for the incentives given to the private provider to reduce costs, there are cases (depending on the impact of consumers' pressure on the private provider's remuneration and on the functional forms of the positive and negative effects of the private provider's cost-cutting efforts) where the contract form such as the concession contract does not dominate the contract form such as the availability contract. In such cases then, a tradeoff occurs between imposing the demand risk on the private provider to raise the accountability of procuring authorities, and not imposing the demand risk on the private provider to raise his cost-cutting incentives. Considering the potentiality of default of procuring authorities tends to make the concession contract be more often optimal than the availability contract, under certain conditions, regarding the cost-cutting incentives of the private provider.

The contribution of the paper is twofold. First, it puts the emphasis on the political accountability, so far neglected, in the alignment on service provision preferences. It sheds some insights on the impact of the contractual design of Public Private Partnerships on this accountability mechanism and questions the trend towards the greater resort to contracts where firms bear little or no demand risk around the world. Second, it contributes to the broader literature on the political economy of government responsiveness. It is in fact related to the literature on voucher provision of public services and demonstrates that empowering consumers of public services strengthens incentives for governments to be responsive.

REFERENCES

- Andersen, Arthur, Enterprise L.S.E., [2000], "Value for Money Drivers in the Private Finance Initiative". *The Treasury Taskforce*, London.
- Athias L. and A. Nunez, [2007], "Winner's Curse in Toll Road Concessions", forthcoming in *Economics Letters*.
- Athias L. and A. Nunez, [2007], "The More The Merrier? Number of Bidders, Information Dispersion, Renegotiation and Winner's Curse in Toll Road Concessions". *Centre for Network Industries and Infrastructure (CNI) Working Paper N°2006-16 & ATOM Working Paper*.
- Athias L. and S. Saussier, [2007], "Un Partenariat Public Privé rigide ou flexible ? Théorie et application aux concessions routières à péage", *Revue Economique*, 58 (3), 565-576.
- Bennett J. and E. Iossa, [2006], "Building and managing facilities for public services". *Journal of Public Economics* 90, 2143-2160.
- Besley T. and R. Burgess, [2001], "Political agency, government responsiveness and the role of the media". *European Economic Review* 45, 629-640.

- Besley T. and R. Burgess, [2002], “The Political Economy of Government Responsiveness: Theory and Evidence from India”, *The Quarterly Journal of Economics*, November.
- Besley T. and M. Ghatak, [2001], “Government versus private ownership of public goods”. *Quarterly Journal of Economics* 116, 1343–1372.
- Besley T. and M. Ghatak, [2003], “Incentives, Choice, and Accountability in the Provision of Public Services”. *Oxford Review of Economic Policy* 19(2).
- Ellman M., [2006], “Does privatising Public Service Provision Reduce Accountability?”. *Working Paper*.
- Engel E., Fischer R., Galetovic A., [2002], “A New Approach to Private Roads”. *Regulation*, Fall 2002, 18-22.
- Engel E., Fisher R., Galetovic A., [2006], “Privatizing Highways in the United States”. *Review of Industrial Organization*, 29, 27-53.
- Engel E., Fisher R., Galetovic A., [2007], “The Basic Public Finance of Public-Private Partnerships”. *Working Paper*.
- Estache A., [2006], “PPI partnerships vs. PPI divorces in LDCs”. *Review of Industrial Organization*, 29, 3-26.
- Flyvbjerg B. and M. Skamris [1997], “Inaccuracy of Traffic Forecasts and Cost Estimates on Large Transport Projects”, *Transport Policy*, 4(3), 141-6.
- Grout P., [1997], “The economics of the private finance initiative”. *Oxford Review of Economic Policy* 13(4), 53-66.
- Guasch J. Luis, [2004], “Granting and Renegotiating Infrastructure Concessions: Doing it Right”. *World Bank Institute*.
- Hart O.D., [2003], “Incomplete Contract and Public Ownership: Remarks, and an Application to Public-Private Partnerships”. *The Economic Journal*, 113, 69-76.
- Hart O., A. Shleifer and R. Vishny, [1997], “The proper scope of government: theory and an application to prisons”. *Quarterly Journal of Economics* 112, 1119-1158.
- HM Treasury, [2000], “Public Private Partnerships”. *The Stationery Office, London*.
- HM Treasury, [2004], “Standardisation of PFI contracts”. *London: HM Treasury*.
- Mc William J. [1997], “A Commissioner’s Tale: Avery Hill Student Village, University of Greenwich”, *Public Money and Management*.
- Pickrell, D. [1990], “Urban Rail Transit Projects: Forecasts Versus Actual Ridership and Cost”. Washington, D.C.. Department of Transportation.

PricewaterhouseCoopers [2005], “Delivering the PPP Promise”, PricewaterhouseCoopers Study.

Wright R., [2007], “Metronet considers review on Tube overspend”. Transport Correspondent, *Financial Times*, April 25.

APPENDIX

A. Proof of Proposition 1

The first-order condition when the private provider bears the demand risk is

$$v'(i) = \frac{2}{2 - \lambda k}, \text{ or, equivalently, } (2 - \lambda k)v'(i(\lambda)) = 2.$$

Taking the derivative with respect to λ yields $(2 - \lambda k)v''(i(\lambda))i'(\lambda) - kv'(i(\lambda)) = 0$

Rearranging and solving for $i'(\lambda)$:

$$i'(\lambda) = \frac{kv'(i(\lambda))}{(2 - \lambda k)v''(i(\lambda))}$$

Since v is concave as well as $0 \leq \lambda \leq 1$ and $0 < k \leq 1$, the denominator is always negative and the numerator is always positive. Therefore, $i'(\lambda)$ is always negative.

B. Proof of Proposition 2

B.1. Proof of proposition 2 ii)

The first-order condition when the private provider bears the demand risk is

$$w'(e) - q'(e) \left[\frac{2\lambda(1 - \lambda)}{(\lambda + 1)} \right] = \frac{2}{\lambda + 1}$$

or, equivalently, $(\lambda + 1)w'(e(\lambda)) - (2\lambda(1 - \lambda)q'(e(\lambda))) = 2$.

Taking the derivative with respect to λ yields

$$(\lambda + 1)w''(e(\lambda))e'(\lambda) + w'(e(\lambda)) - (2\lambda(1 - \lambda)q''(e(\lambda))e'(\lambda) - (2 - 4\lambda)q'(e(\lambda))) = 0.$$

Rearranging and solving for $e'(\lambda)$:

$$e'(\lambda) = \frac{(2 - 4\lambda)q'(e(\lambda)) - w'(e(\lambda))}{(\lambda + 1)w''(e(\lambda)) - 2\lambda(1 - \lambda)q''(e(\lambda))}$$

Since w is concave and q is convex (as well as $0 \leq \lambda \leq 1$), the denominator is always negative. Since $w' - q'$ is always positive, the numerator is also always negative for $\lambda > \frac{1}{4}$.

Therefore, when $\lambda > \frac{1}{4}$, $e'(\lambda)$ is always positive.

C. Proof of Proposition 5

The first-order condition is

$$\gamma w'(e(\gamma)) = 1$$

Taking the derivative with respect to γ yields

$$\gamma w''(e(\gamma))e'(\gamma) + w'(e(\gamma)) = 0$$

Rearranging and solving for $e'(\gamma)$:

$$e'(\gamma) = -\frac{w'(e(\gamma))}{\gamma w''(e(\gamma))}$$

Since w is concave, the denominator and the numerator are also always negative. Therefore, $e'(\gamma)$ is always positive.